



SMLC[®]

SHRI MAHALUXMI CHEMICALS

Quality in everything we do.

BRANCHES:

RAMESHWARAM ENTERPRISES

New Delhi

SML INDUSTRIES

Pune, Maharashtra

SMLC

Jaipur, Rajasthan

SMLC

Pune, Maharashtra

SMLC

Rudrapur, Uttarkhand

SMLC

Karnal, Haryana

SMLC

Faridabad, Haryana

SMLC

Banglore

WWW.SMLCUNIVERSAL.COM

SHUBHAM GARGOTE

MAIL ID - EQ.SALES@SMLCUNIVERSAL.COM

CONTACT - 8484818721

Customers



ABOUT US

- We provide precise dosing solutions for Industrial Adhesives, Sealants and Chemicals
- We offer Process Automation Solutions, Assembly Automations
- Material handling Automations



PRODUCTS OFFERED

- Meter Mix Dispensing Machines – Automotive components, Air Filter, Capacitor, SPDs, LED Drivers, Transformers and special applications
- Dispensing Accessories
- Resin and Filler Mixing Automation
- Robotic Applicators- Sealant Metering and Dispensing
- Material Handling Systems – Conveyors, Pick and Place unit
- Special Purpose Machine– Customized and Turnkey Solution- Robotic Welding
- Ovens
- Hepa Filter Machines- PU glue dispensing, Silicone Gel Dispensing



WHY YOU SHOULD WORK WITH US..

- Experience in Dispensing field
- Process knowledge
- Good Design Capabilities, Strong team
- 75+ Machines sold every year for 2 component Dosing
- Assured After Sales Support
- Competitive spare part cost
- Ability and willingness to take challenges
- Turn Key – End to End Solution



METER MIX DISPENSER- EPOXY/ PU MIXING

We offer

1. Fixed ratio – Piston pump machine
 2. Variable ratio- Piston & Gear type both
- Mixing Heads
Static/Dynamic



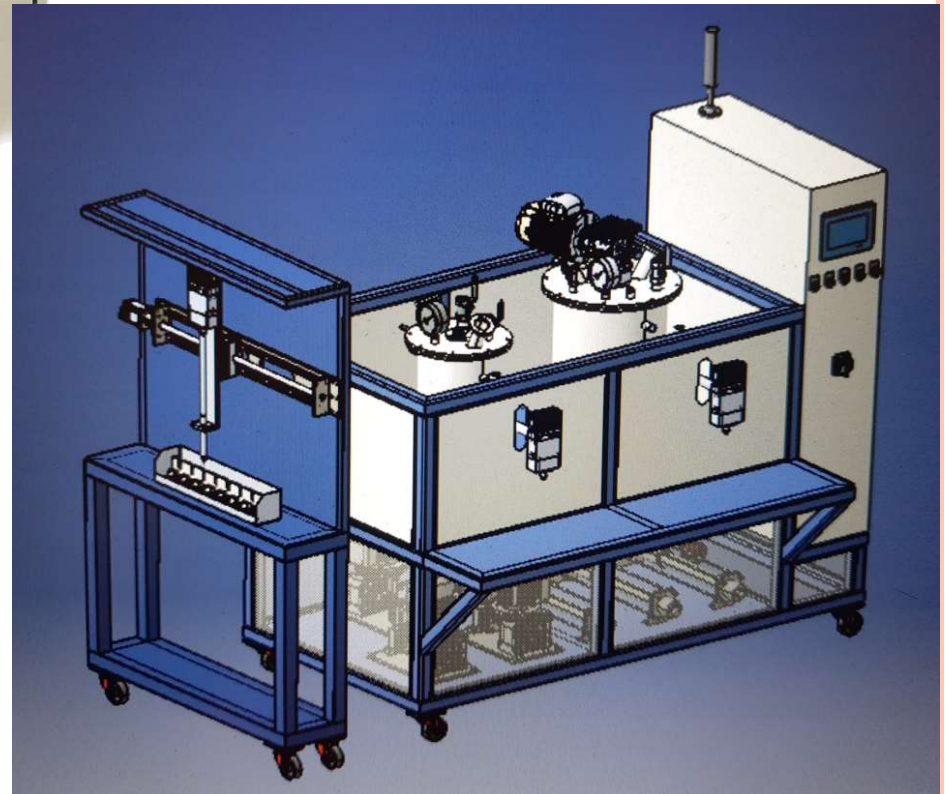

METERING TECHNOLOGIES

VARIABLE RATIO METERING MACHINE

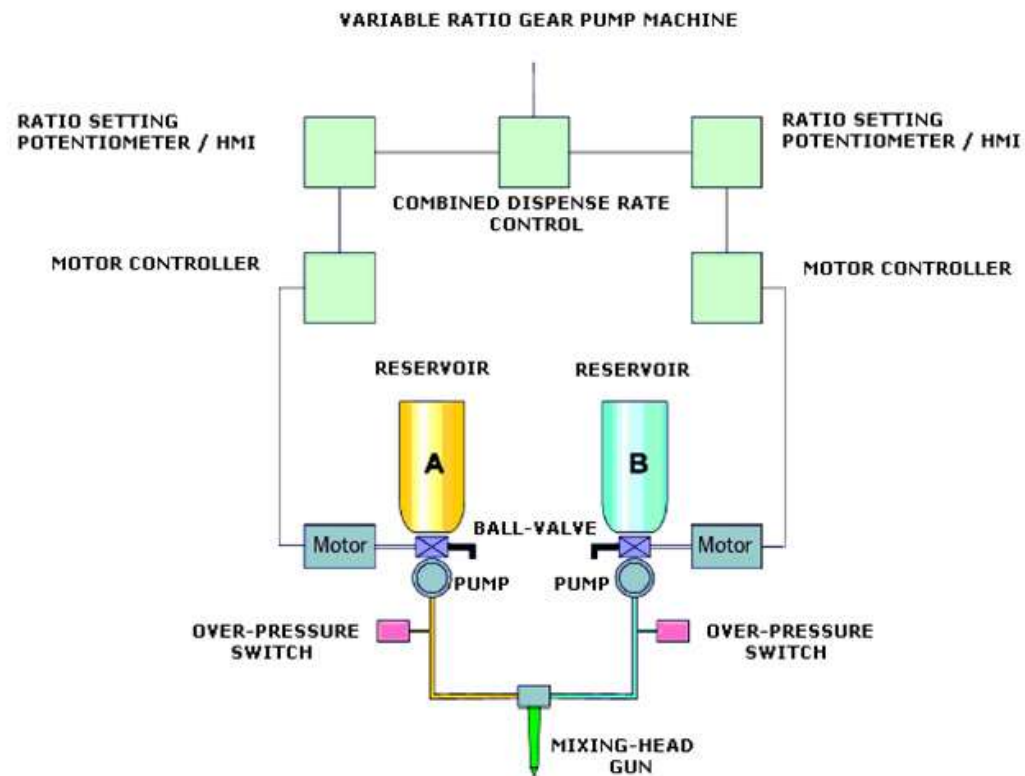

PISTON METERING ARRANGEMENT

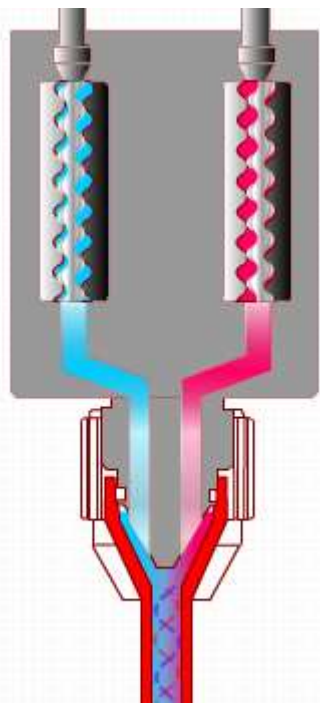

Screw Metering Arrangement

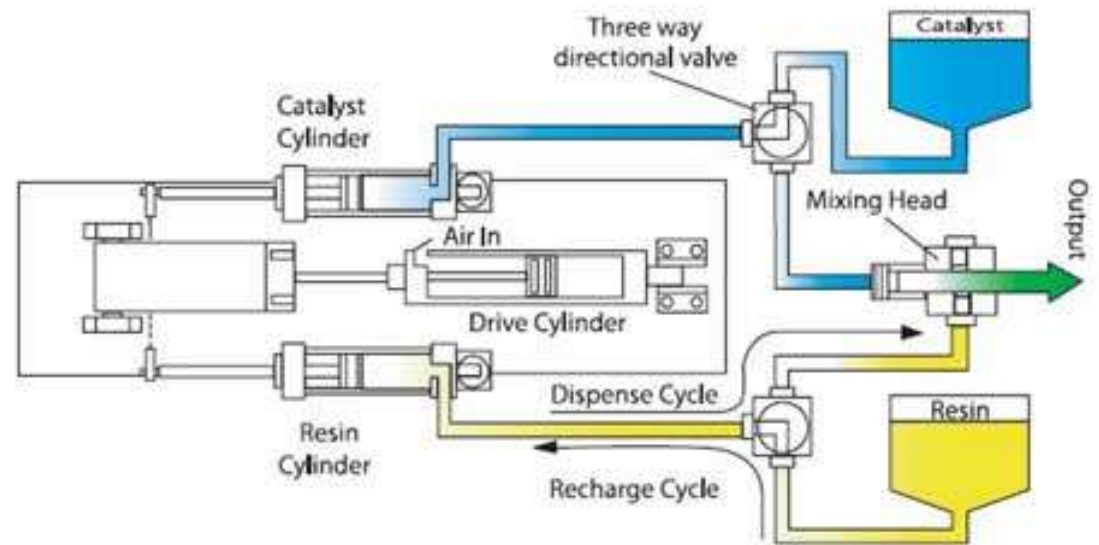

FEATURES

CONFIGURATION OF METER MIX DISPENSER

- 2/3/4 Tank System
- Optional: Tank Level Sensor, Flow Sensor
- Single or Multi Head Dispensing
- Precise Metering Pumps
- Variable Flow rate, Starting from 0.5g/sec to 70g/sec.
- Variable Ratio Machine, Suitable for material changeover
- Non Drip Dispensing Gun
- Inbuilt Temperature monitoring and control in PLC
- Precise Temperature control
- Optional Digital Pressure sensor for material pressure monitoring



SPECIAL FEATURES

- Flow monitoring sensors available to monitor the precise dosing quantity
- Auto Ratio correction facility available
- Auto Material Loading without operator interference
- Material continuous level monitoring in Tank available



Robotic systems

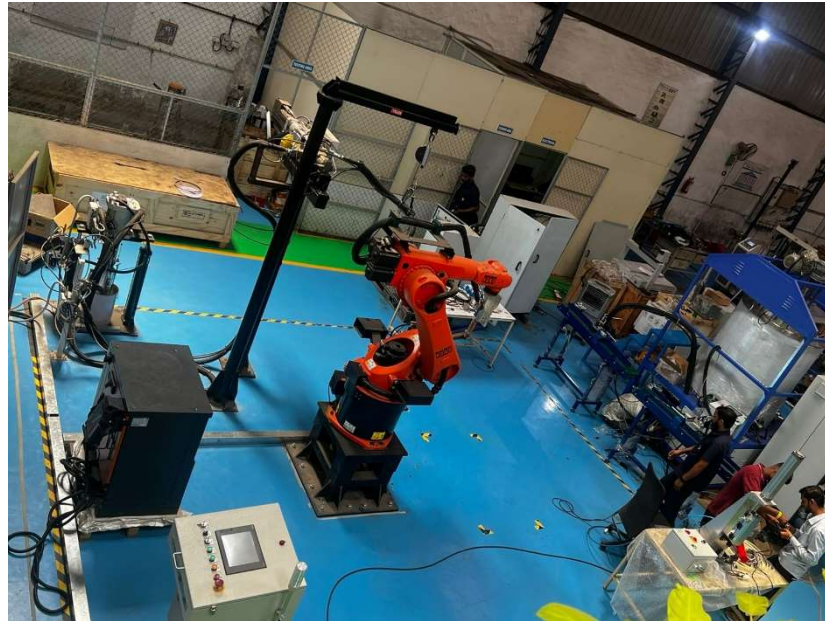

APPLICATIONS HANDLED

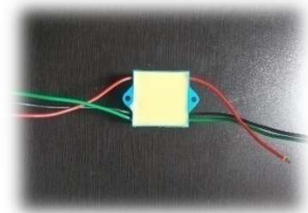
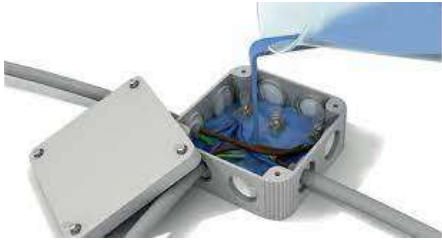

OVENS— CURING PREHEATING



Conveyorised Oven



Batch Type Oven with
Pneumatic UP/DOWN



Batch Type Oven

COMPLETE ASSEMBLY SOLUTION- PREHEATING, DISPENSING, CURING, COOLING

